

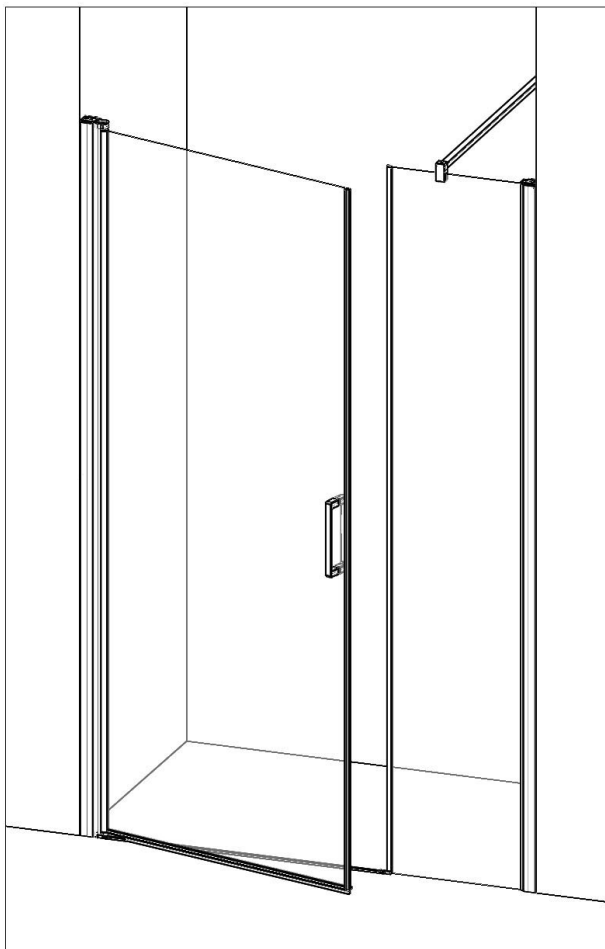

**F** NOTICE DE MONTAGE  
**GB** INSTALLATION INSTRUCTIONS  
**I** ISTRUZIONI DI MONTAGGIO  
**NL** INSTALLATIE VOORSCHRIFTEN  
**D** INSTALLATIONSANLEITUNG

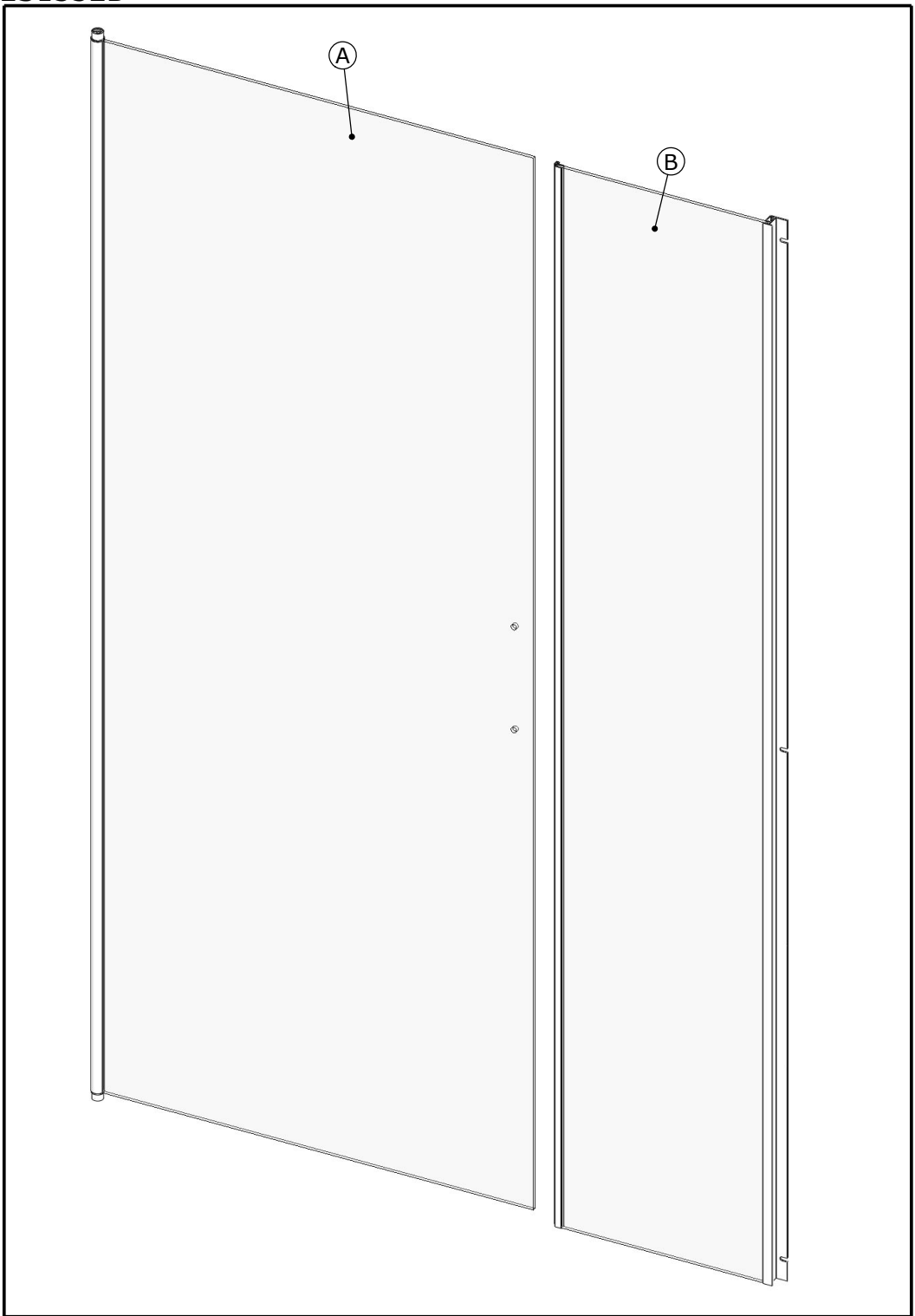

- Attention aux étapes :
- Check installation steps :
- Attenzione ai passi :
- Aandacht voor de stappen :
- Achtung vor den Schritten :

P. 6 - 20 - 24

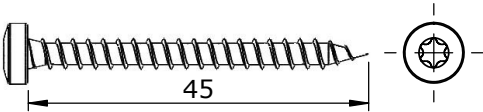
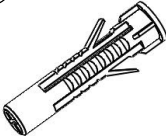
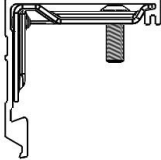
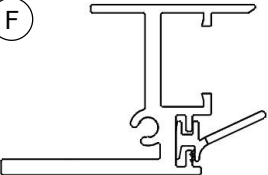
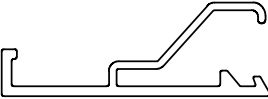
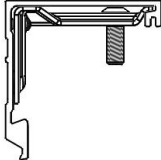
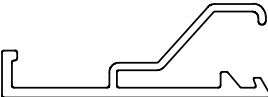
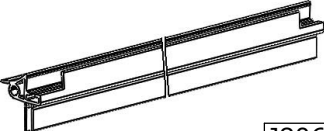
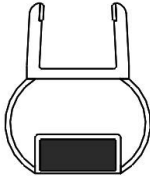
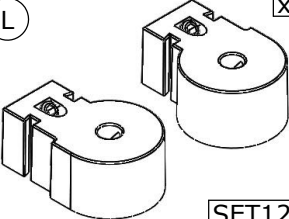
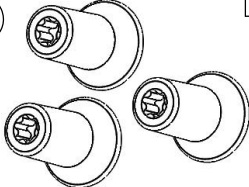
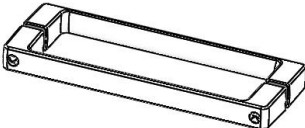

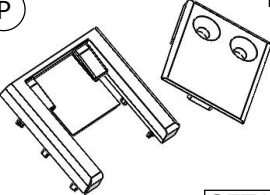
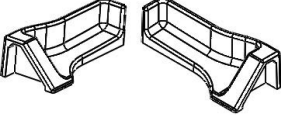
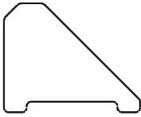
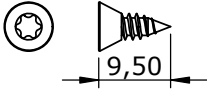
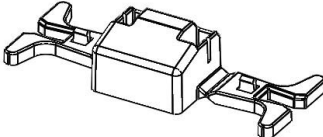
<p><b>C</b> <math>\varnothing 3.5\text{mm}</math> x6</p>  <p>45</p> <p>VIS231</p>	<p><b>D</b> x6</p>  <p>CHE02</p>	<p><b>E</b> x1</p>  <p>Lg = 2000mm 6268</p>
<p><b>F</b> x1</p>  <p>Lg = 2000mm 6272</p>	<p><b>G</b> x1</p>  <p>Lg = 2000mm 6270</p>	<p><b>H</b> x1</p>  <p>Lg = 1980mm 6268</p>
<p><b>I</b> x1</p>  <p>Lg = 1980mm 6270</p>	<p><b>J</b> x1</p>  <p>J806</p>	<p><b>K</b> x1</p>  <p>Lg = 1962mm AI178</p>
<p><b>L</b> x1</p>  <p>SET128</p>	<p><b>M</b> x2</p>  <p>SET134</p>	<p><b>N</b> x1</p>  <p>PGN49</p>
<p><b>O</b> x1</p>  <p>PPL1248</p>	<p><b>P</b> x2</p>  <p>SET137</p>	<p><b>Q</b> x1</p>  <p>SET140</p>
<p><b>R</b> x1</p>  <p>6285</p>	<p><b>S</b> <math>\varnothing 3.5\text{mm}</math> x2</p>  <p>9,50</p> <p>VIS261</p>	<p><b>T</b> x2</p>  <p>PPL1339</p>

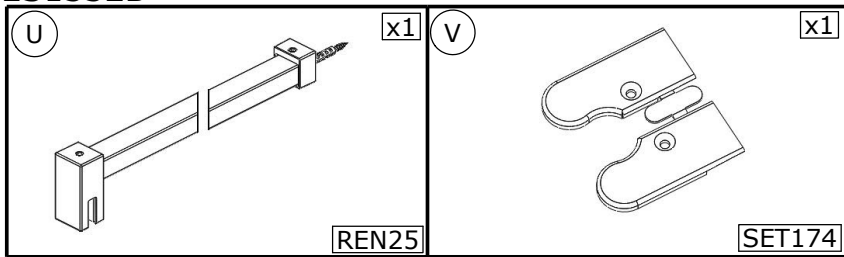

- Les quantités données sont les quantités utiles au montage. les sachets fournis contiennent des pièces supplémentaires.
- The quantities given are what are required for the installation. There may be some surplus in the package provide.
- Le quantità fornite sono le quantità necessarie al montaggio. I sacchetti forniti contengono pezzi supplementari.
- De aangegeven aantallen zijn vereist voor de montage. De verpakking bevat extra onderdelen.
- Die Mengenangaben beziehen sich auf die für die Montage nötigen Teile. Eventuell weitere beige packte Teile ignorieren.

**F** Matériel nécessaire **GB** Tools required

**I** Materiale necessario **NL** Benodigd gereedschap **D** Benötigte Werkzeuge

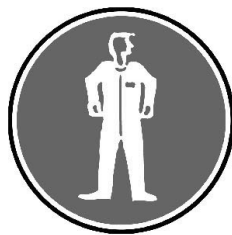
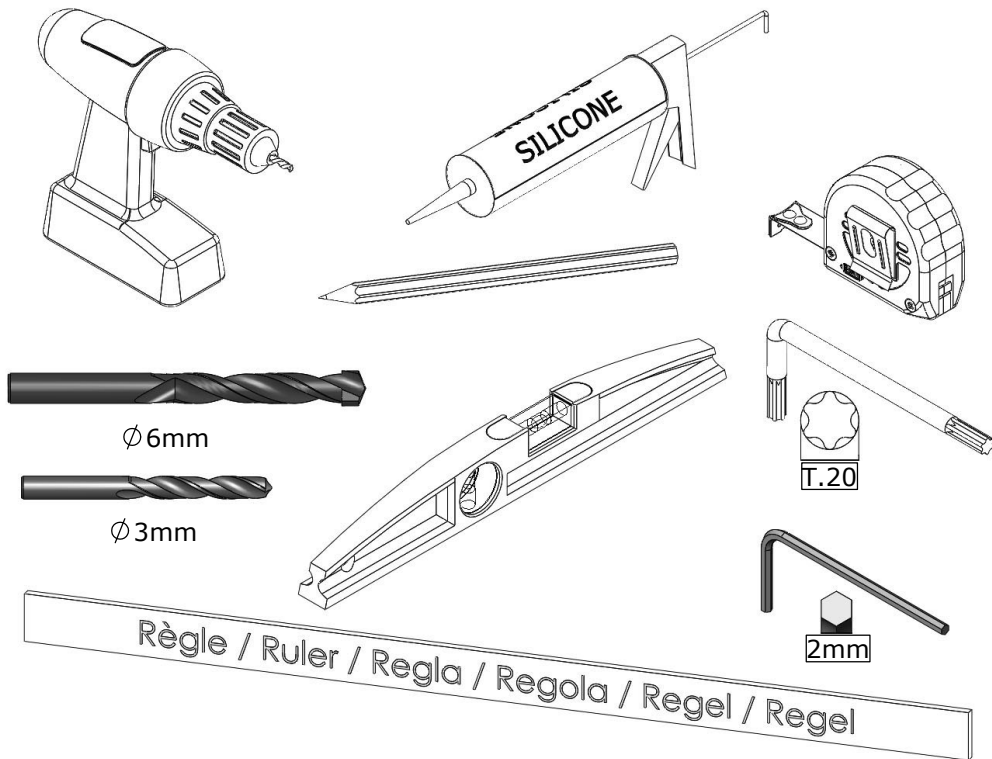

● REVERSIBILITE ● REVERSIBILITY  
 ● REVERSIBILITA ● OMKEERBAARHEID ● WAHLWEISE MONTAGE

- MONTAGE A GAUCHE  
 ● LEFT HAND  
 ● MONTAGGIO A SINISTRA  
 ● MONTAGE LINKS  
 ● MONTAGE LINKS

- MONTAGE A DROITE  
 ● RIGHT HAND  
 ● MONTAGGIO A DESTRA  
 ● MONTAGE RECHTS  
 ● MONTAGE RECHTS

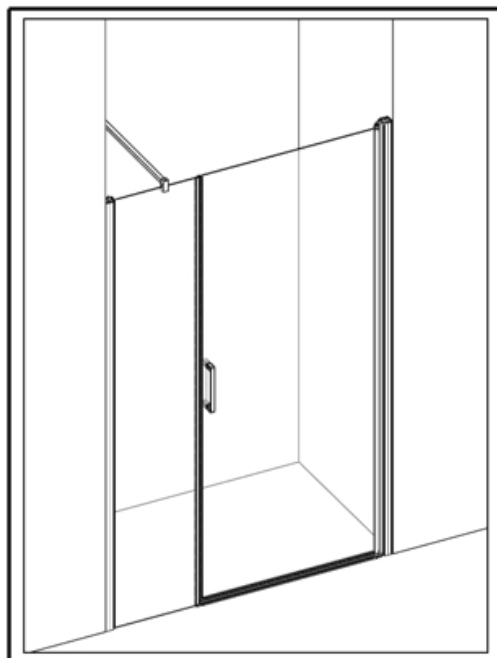
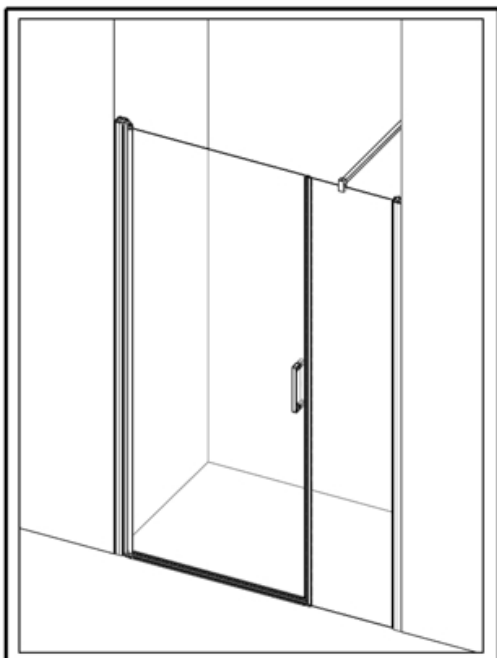

● Vous avez la possibilité de réaliser un montage à droite ou un montage à gauche. Notre notice d'installation décrit un montage à gauche. Si vous voulez réaliser un montage à droite, il vous suffit d'inverser le montage.

● This cubicle can be installed either left or right hand. These installation instructions show a left hand installation.

● Avete la possibilità di effettuare il montaggio a destra o a sinistra. Il nostro manuale descrive il montaggio a sinistra. Se volete realizzare il montaggio a destra è sufficiente invertire varie fasi di montaggio.

● U kunt de douchecabine rechts of links monteren. Onze handleiding beschrijft de links montage van de cabine. Keer de montage om als u de cabine rechts wilt monteren.

● Sie haben die Möglichkeit, eine Montage auf der linken Seite oder eine Montage auf der rechten Seite durchzuführen. Unsere Montageanleitung beschreibt eine Montage auf der linken Seite. Wenn Sie die Montage lieber auf der rechten Seite durchführen wollen, müssen Sie nur den Montageprozess umkehren.

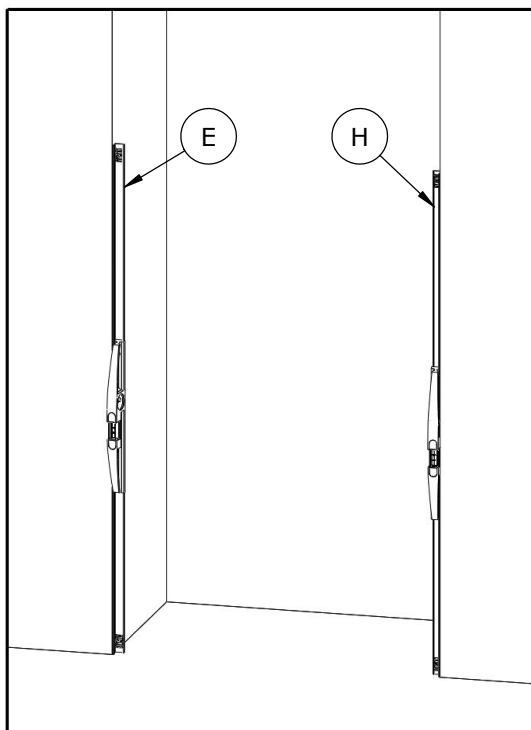

- F Si receveur
- GB If shower tray
- I Se piatto
- NL Als douchebak
- D Wenn Duschanne

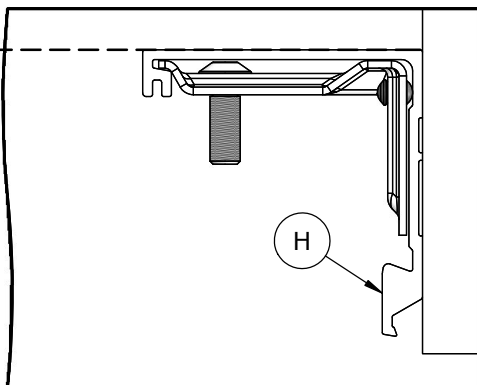
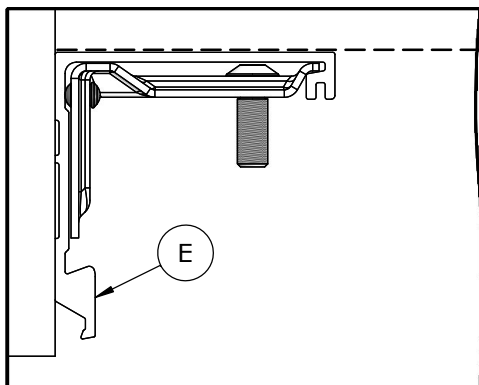
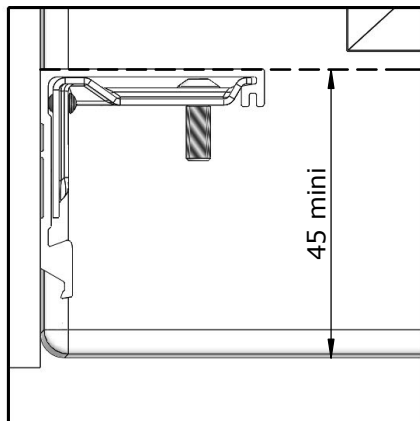

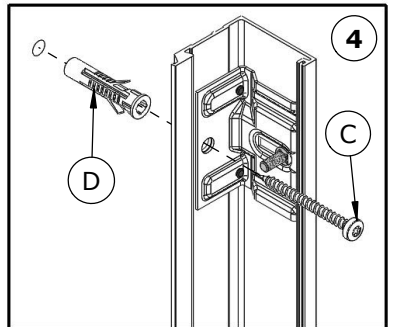
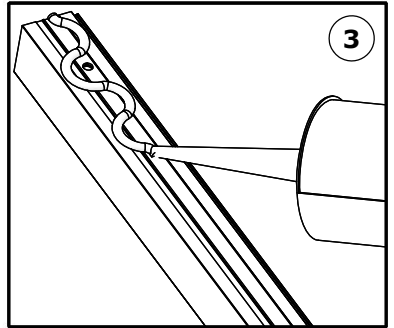
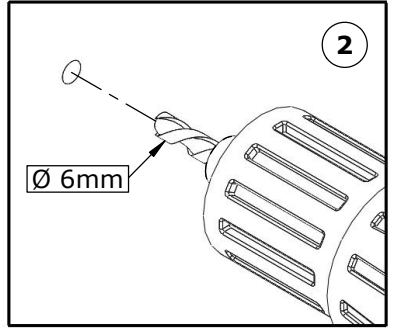
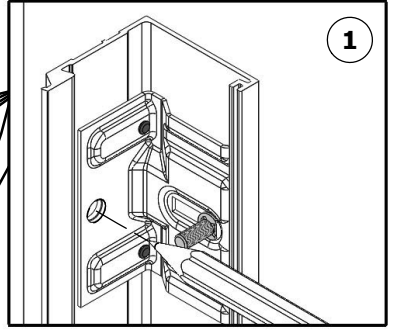
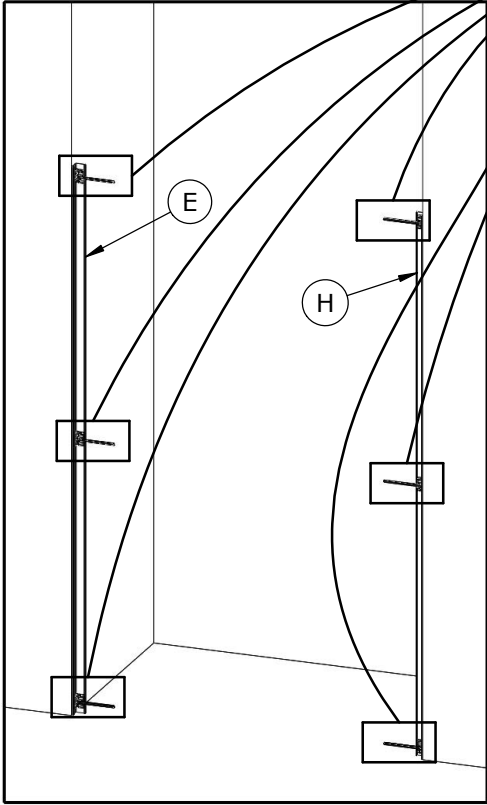

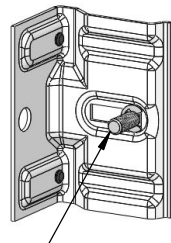
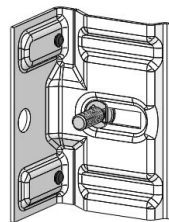
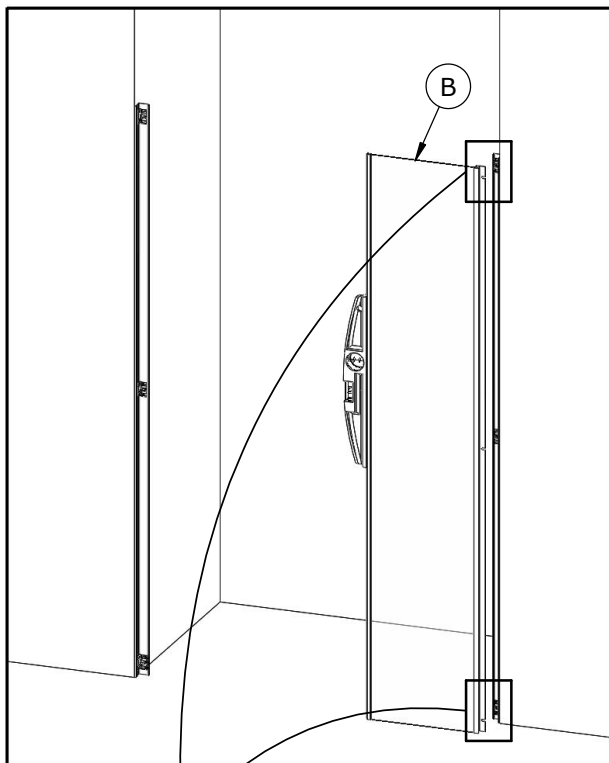

- Si nécessaire, desserrer, régler puis resserrer
- If necessary, loosen, adjust and retighten
- Se necessario, allentare, regolare e stringere
- Draai los, indien nodig, stel af en draai vervolgens weer vast
- Falls erforderlich, lösen, einstellen und wieder festziehen

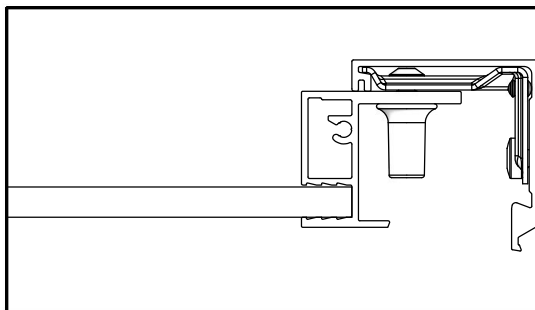
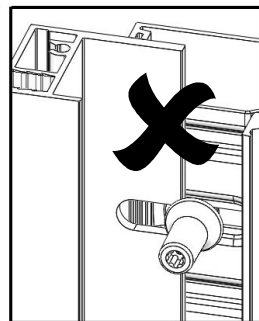
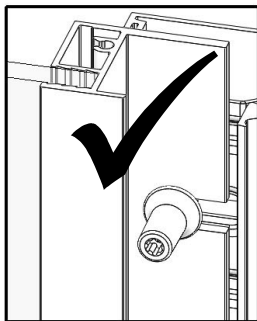
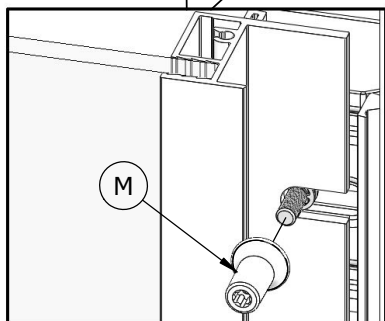



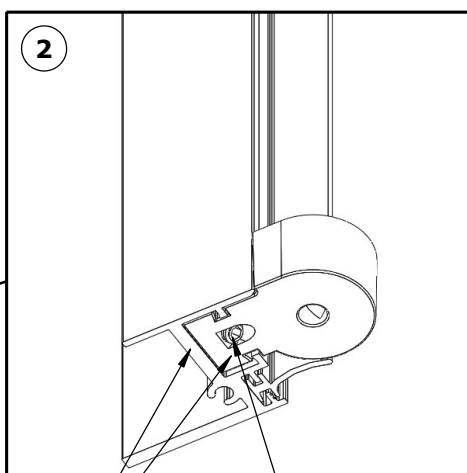
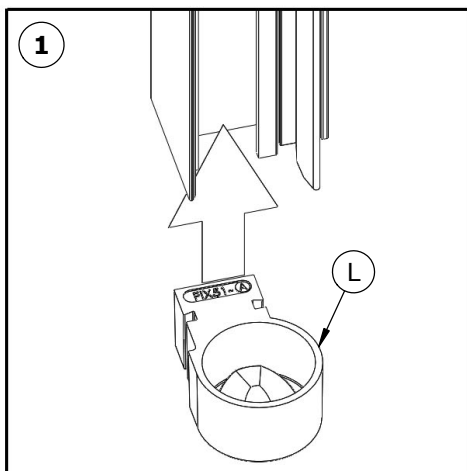
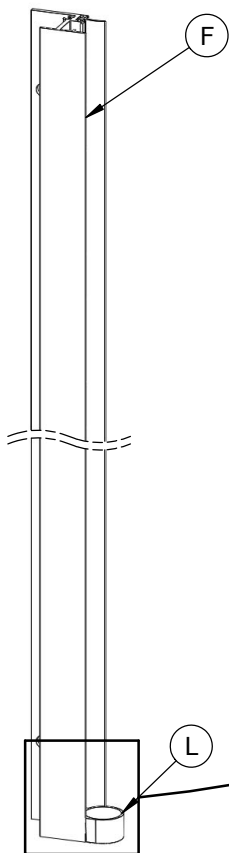

- (L) affleurent
- (L) Flush
- (L) Lavare
- (L) Uitstekend
- (L) Bündig

- F Serrer
- GB Tighten
- T Serrare
- NL Vastdraaien
- D Festziehen

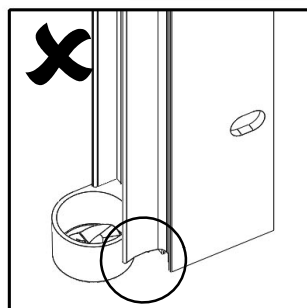
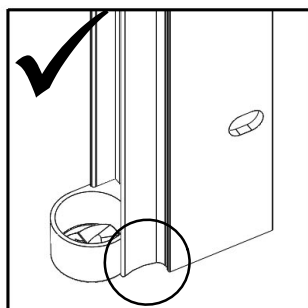

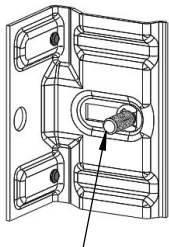
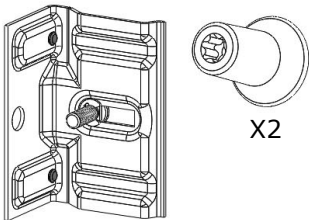

- Si nécessaire, desserrer, régler puis resserrer
- If necessary, loosen, adjust and retighten
- Se necesario, allentare, regular e stringere
- Draai los, indien nodig, stel af en draai vervolgens weer vast
  - Falls erforderlich, lösen, einstellen und wieder festziehen

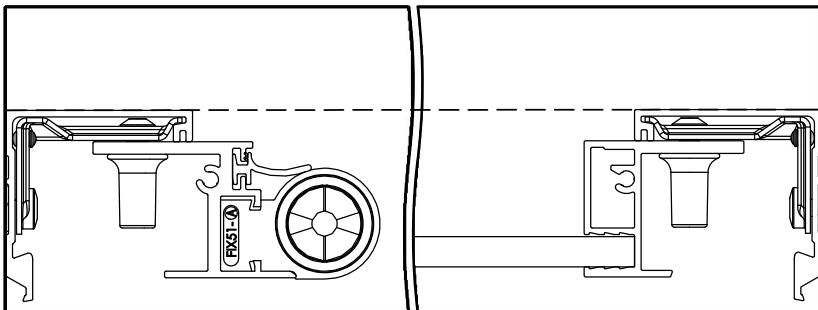
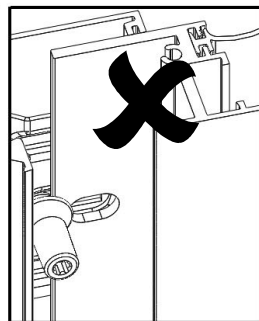
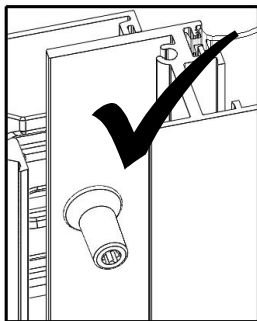
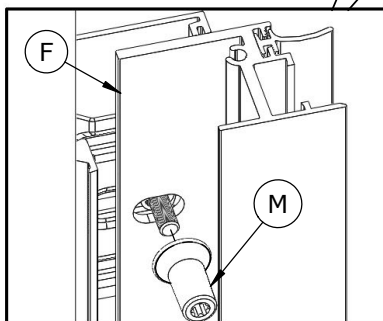
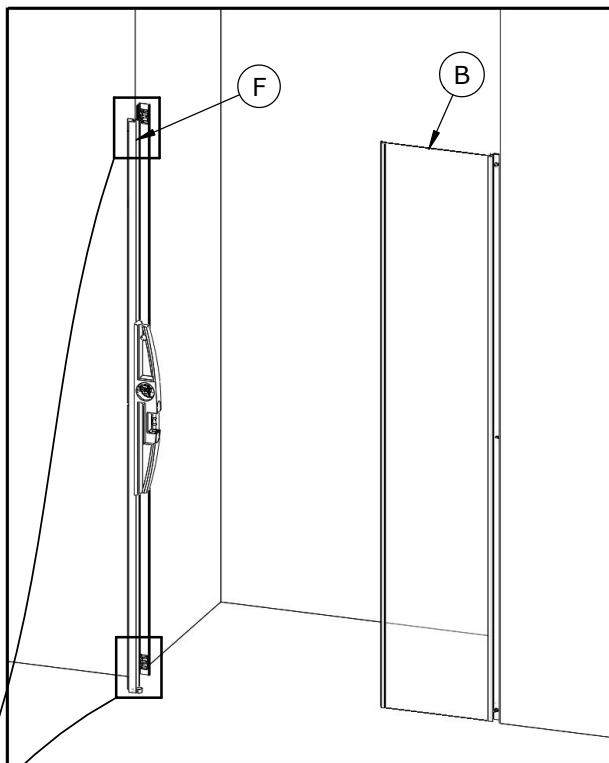

- <sub>F</sub> (N) Voir notice concernée
- <sub>GB</sub> (N) See installation instructions required
- <sub>I</sub> (N) Vedere manuale appropriato
- <sub>NL</sub> (N) Zie de bijbehorende montagehandleiding
- <sub>D</sub> (N) Siehe betreffende Anleitung

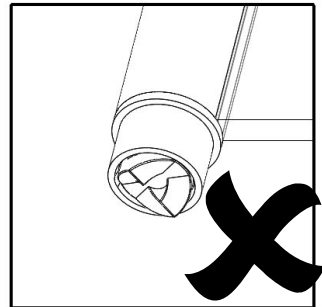
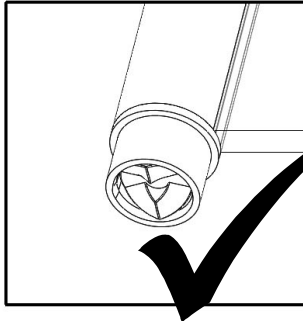
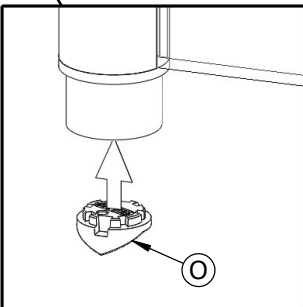
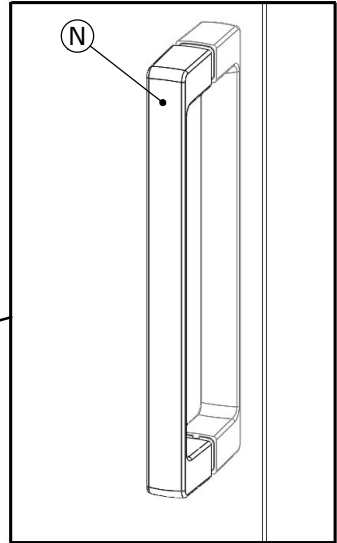
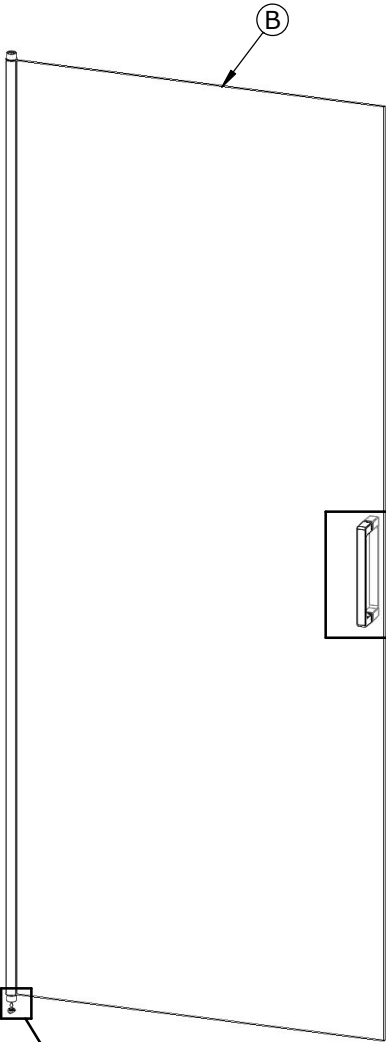

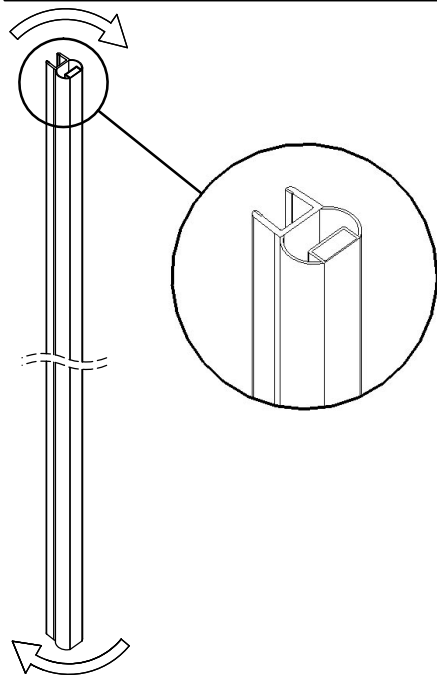
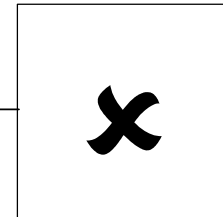
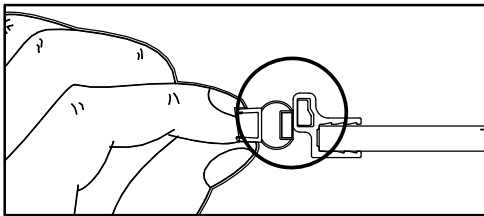
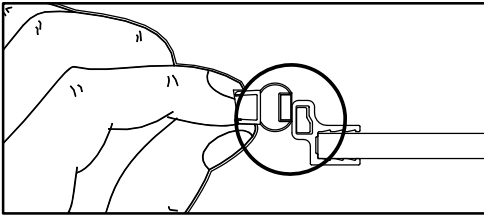
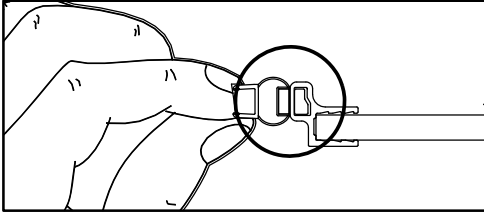

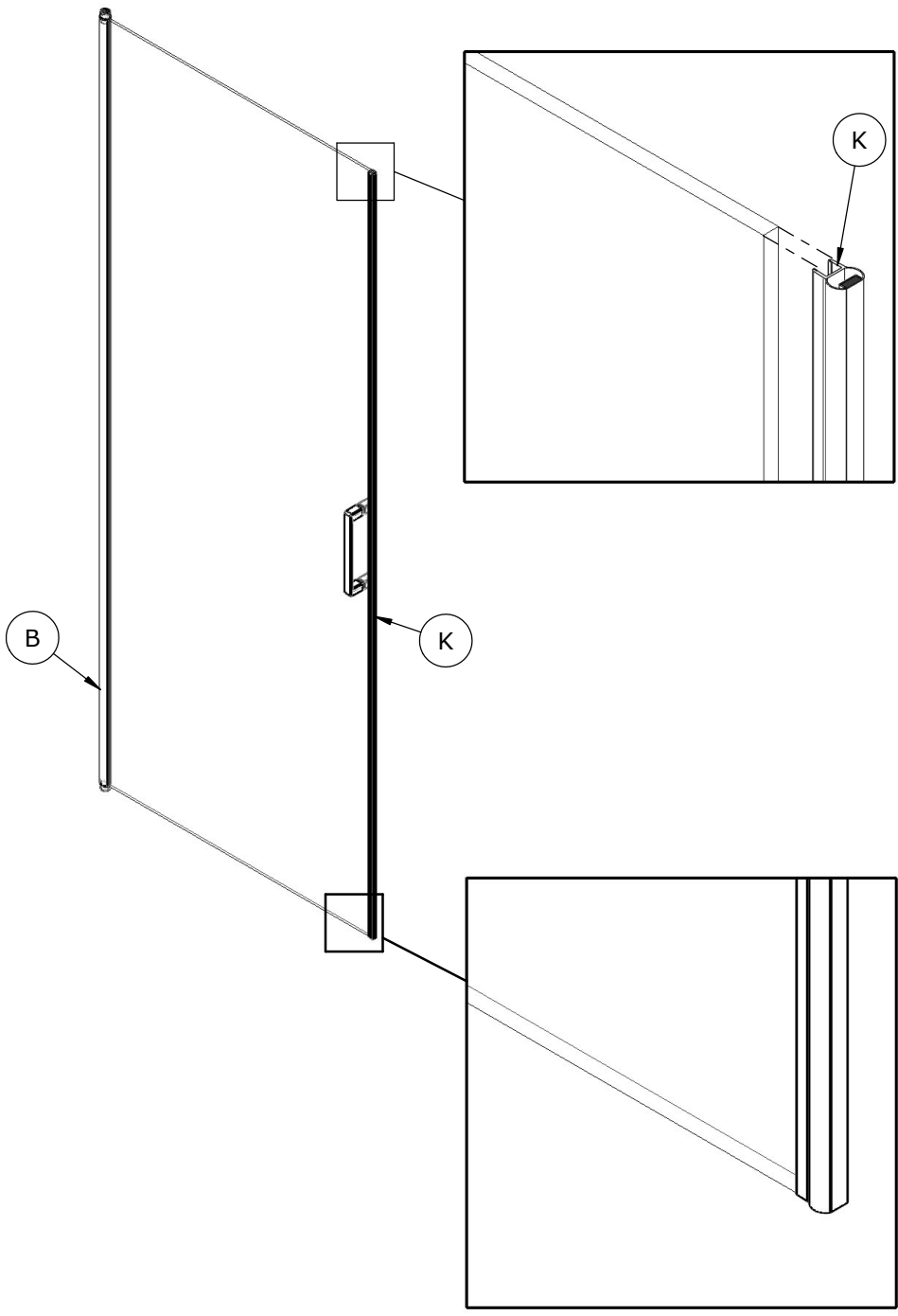

- Réglages des portes ● Adjusting the doors ● regolazione porte
- Deuren afstellen ● Ausrichten und Einstellen der Tür

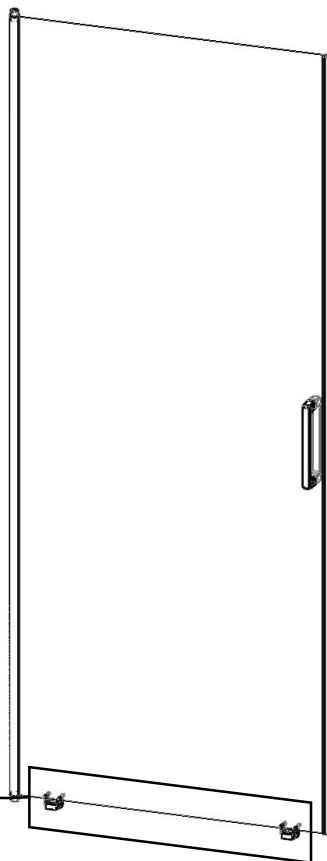
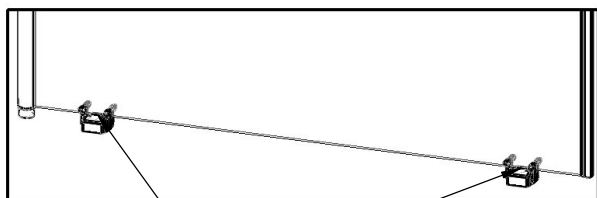
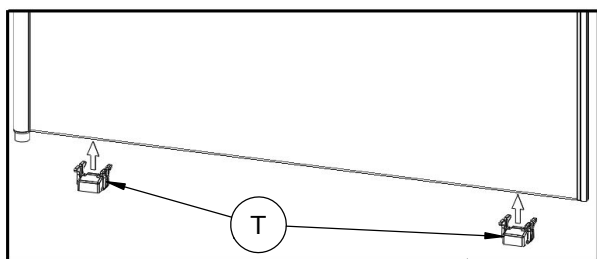
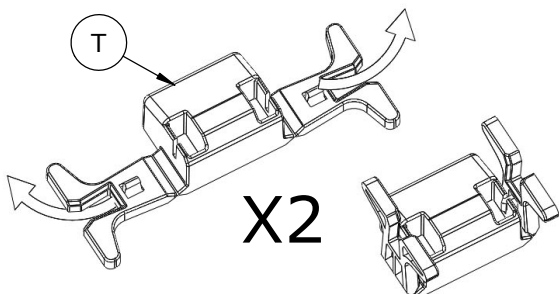

- Mettre en contact
- Put in contact
- Mettere in contatto
- Mensen in contact te brengen
- Kontakte knüpfen

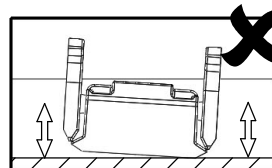
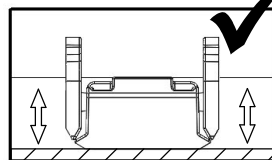

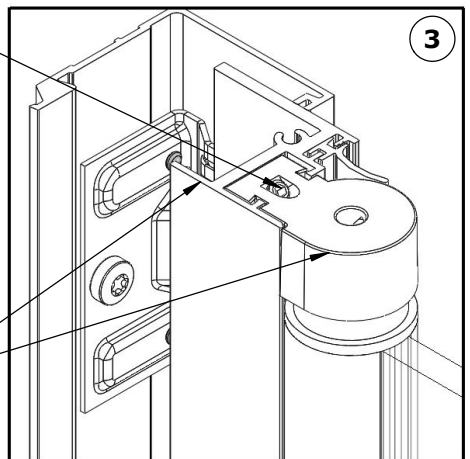
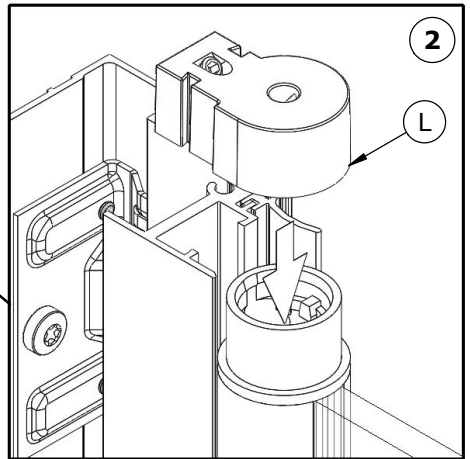
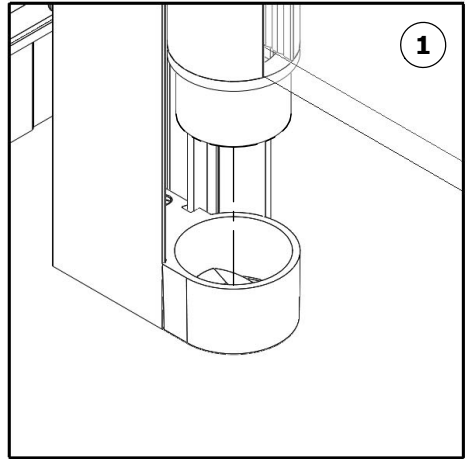
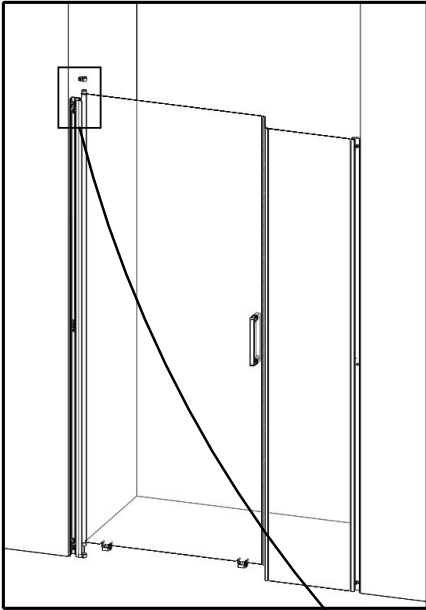

● Serrer fort ● Tighten tightly  
 ● Serrare bene  
 ● Draai stevig vast ● Fest anziehen

● Affleurant ● Flush  
 ● Affioramento  
 ● Doorspoelen ● Bündig

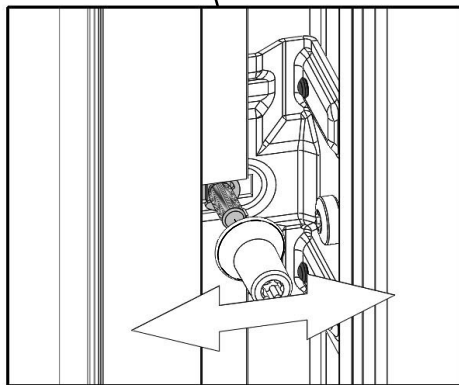
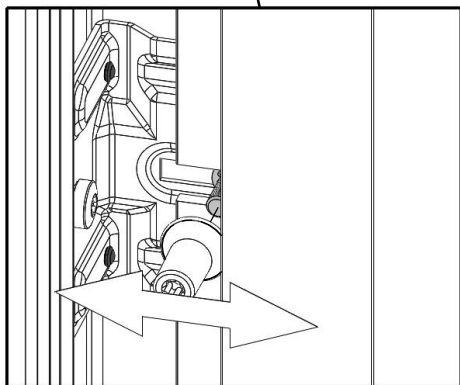
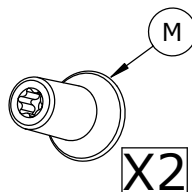
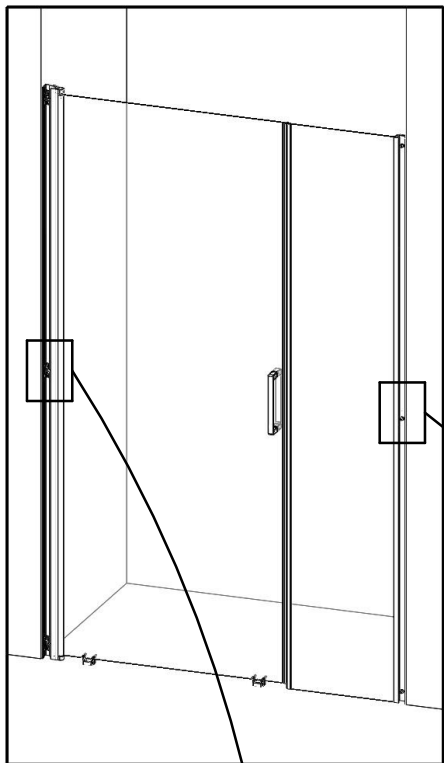

- Si nécessaire, desserrer, régler puis resserrer
- If necessary, loosen, adjust and retighten
- Se necesario, allentare, regolare e stringere
- Draai los, indien nodig, stel af en draai vervolgens weer vast
- Falls erforderlich, lösen, einstellen und wieder festziehen



- Mettre (G) et (I) ● Put (G) and (I)
- Mettere (G) e (I)
- Zet (G) en (I) ● Put (G) und (I)

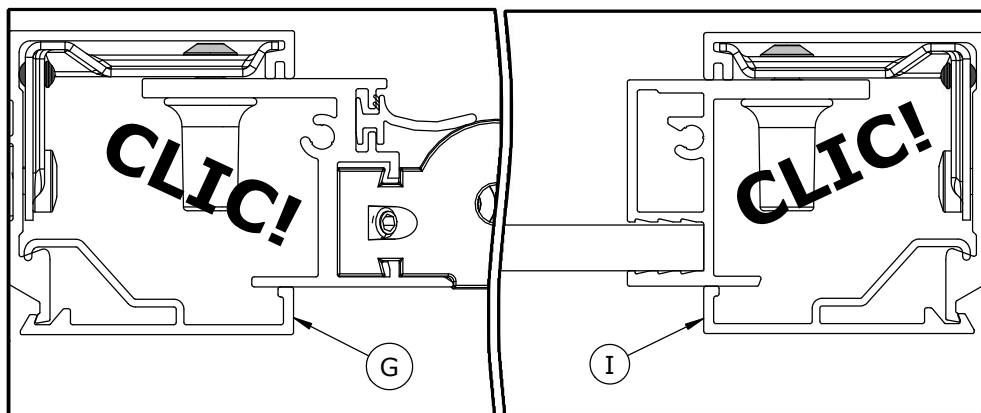
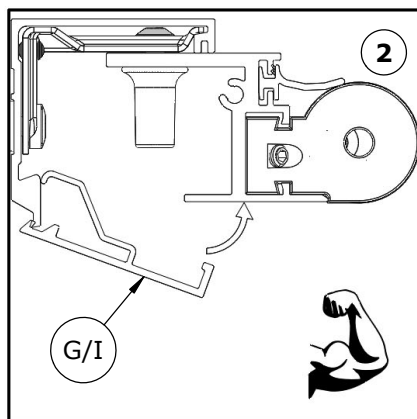
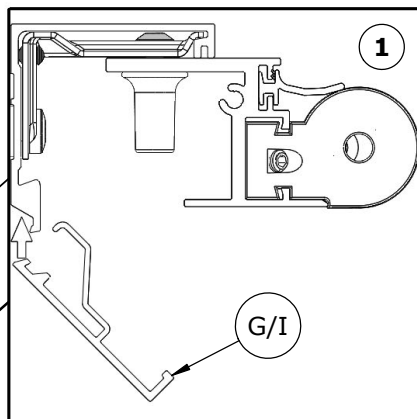
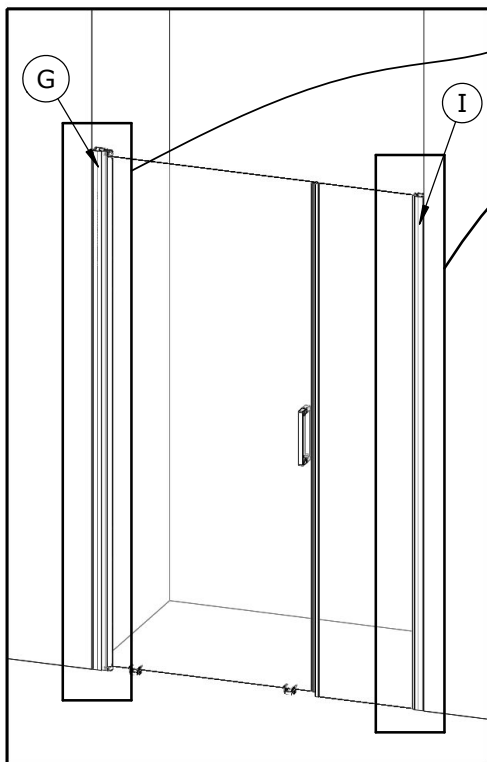

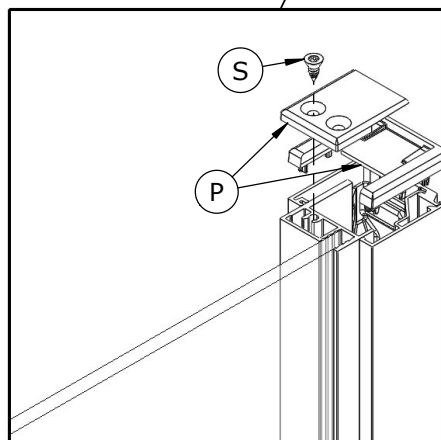
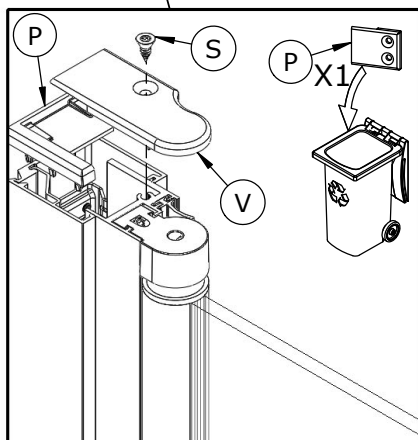
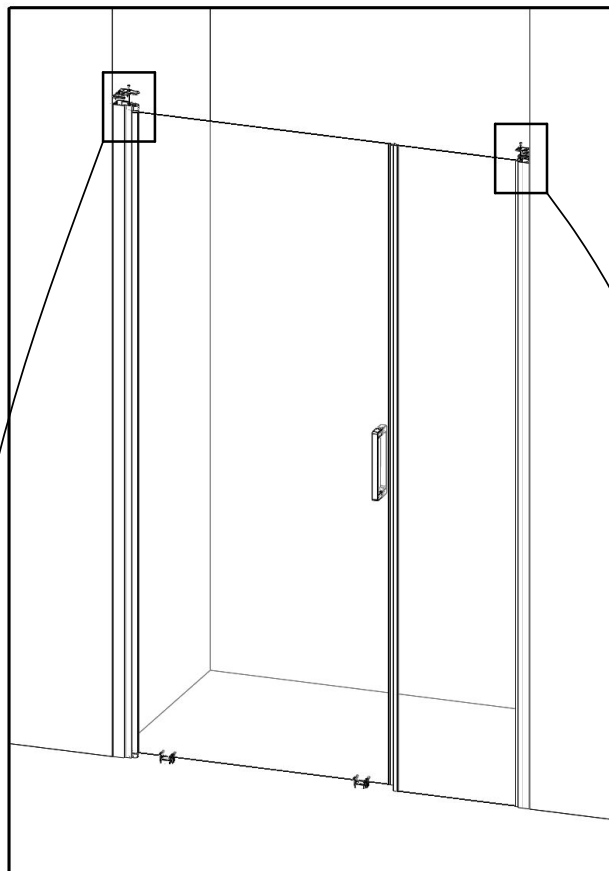

- Retirer (T) ● Remove (T) ● Togliere (T)  
● Verwijderen (T) ● Entfernen (T)

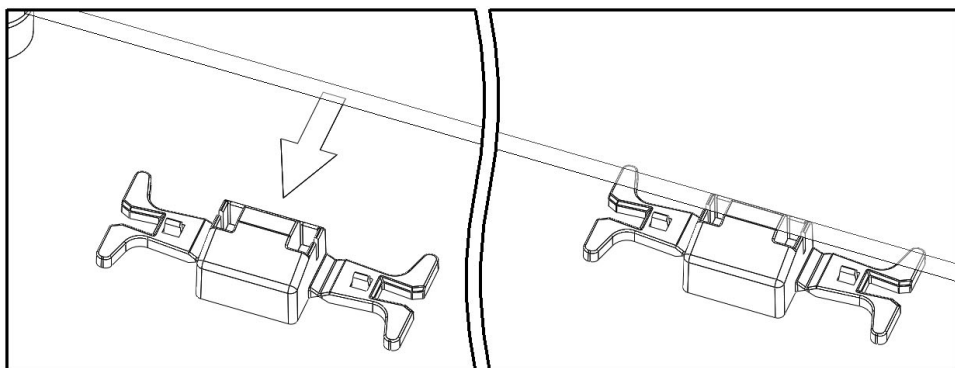
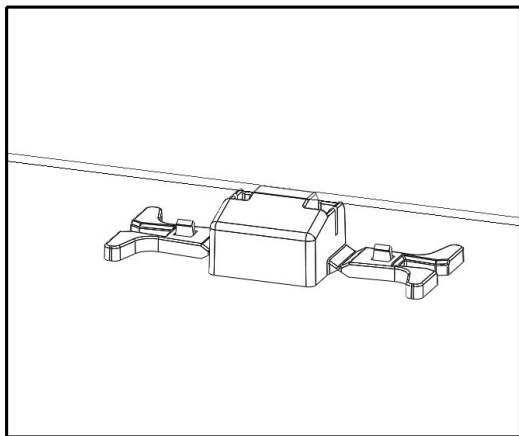
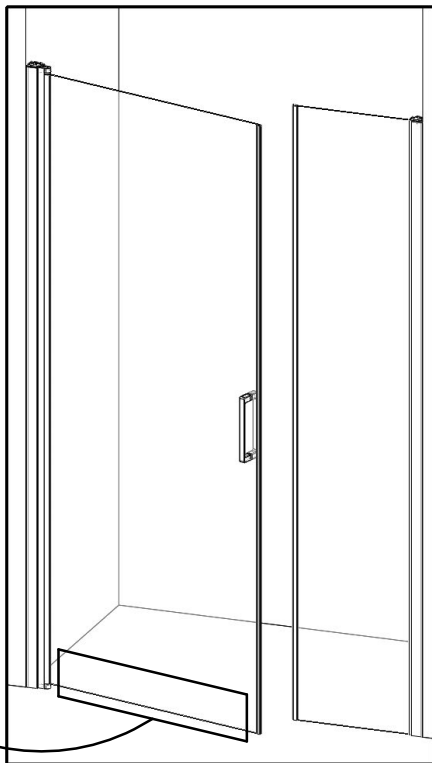
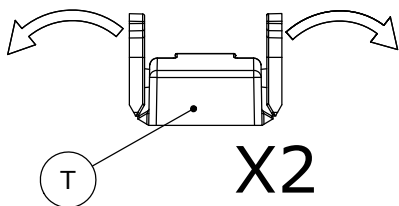

● Intérieur ● Inside  
 ● Interno  
 ● Binnenkant ● Innen



J

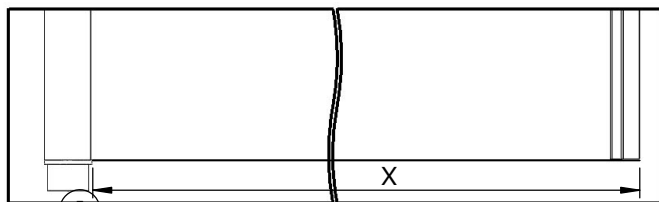
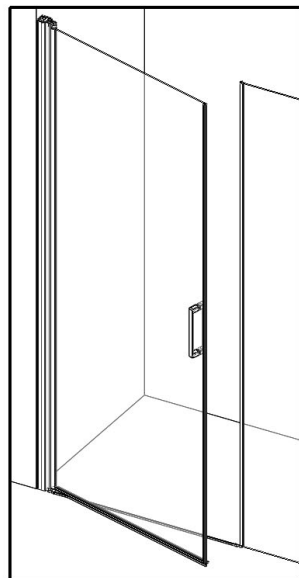
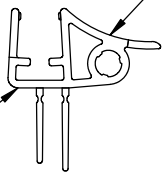

J

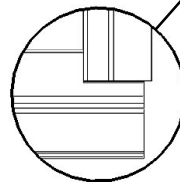
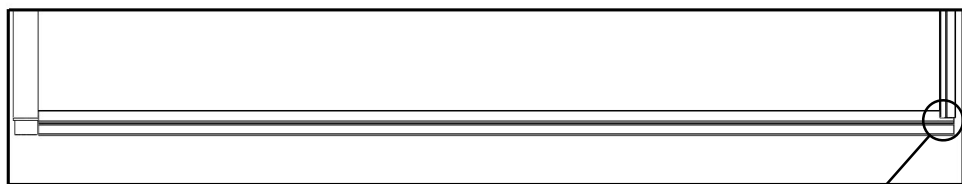
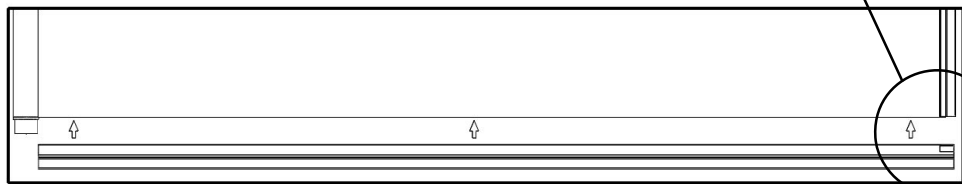
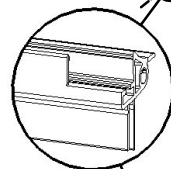
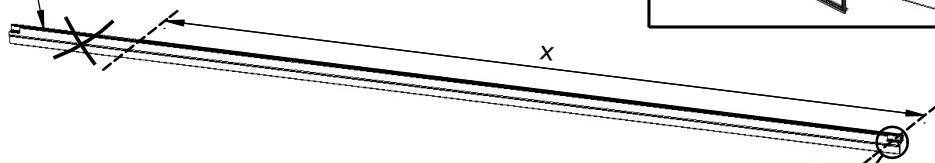

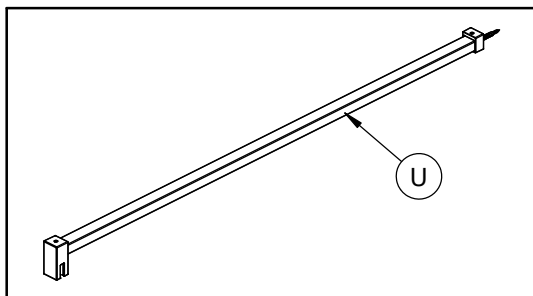

- Ⓐ Voir notice concernée
- Ⓑ See installation instructions required
- Ⓒ Vedere manuale appropriato
- Ⓓ Zie de bijbehorende montagehandleiding
- Ⓔ Siehe betreffende Anleitung

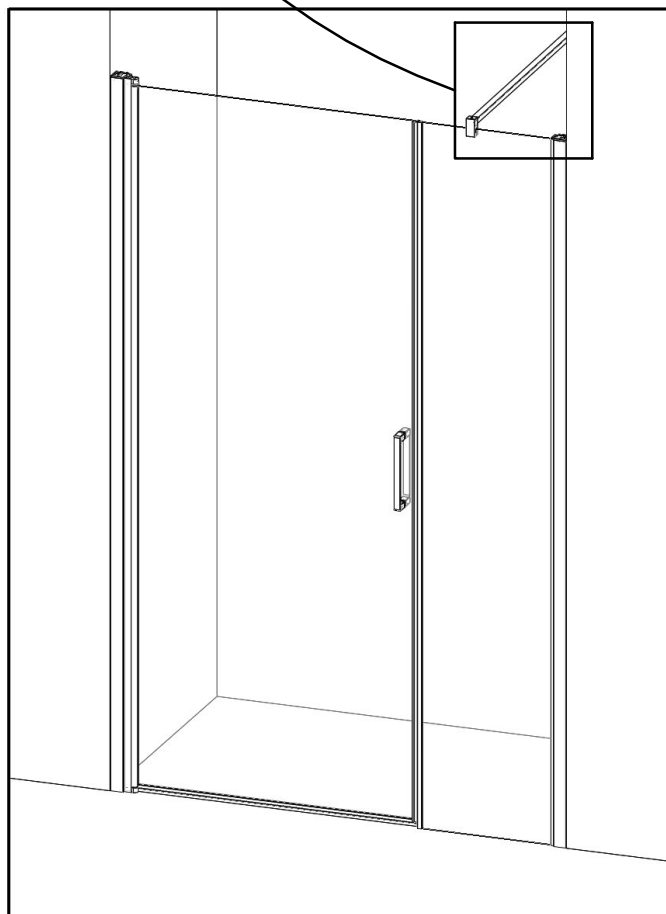

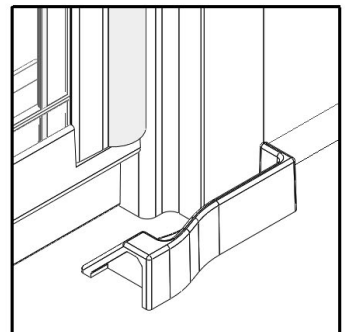
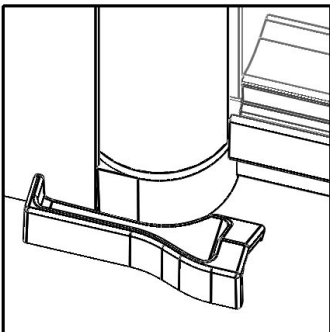
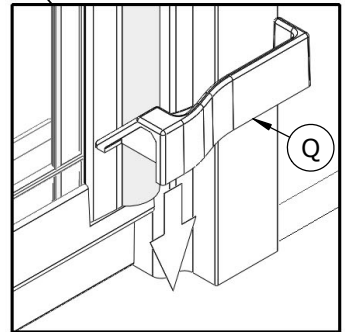
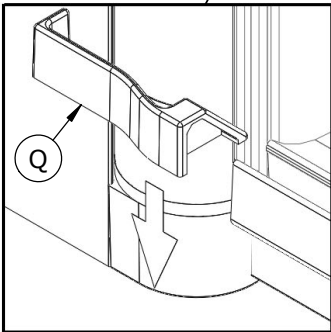
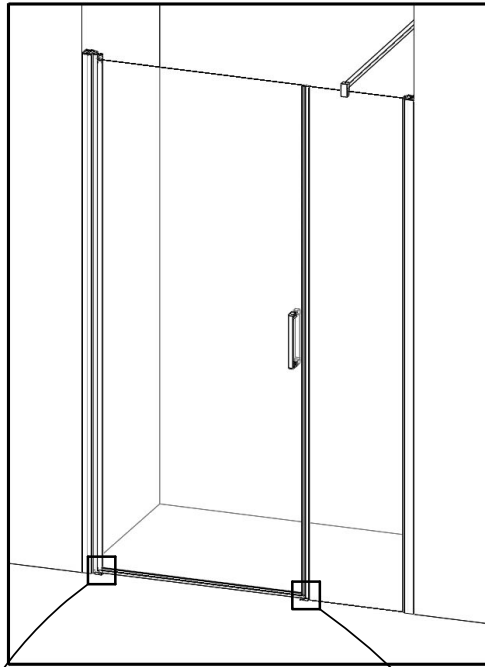

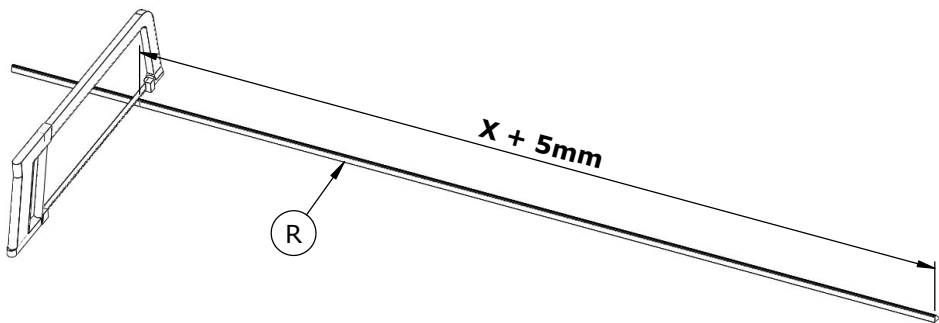
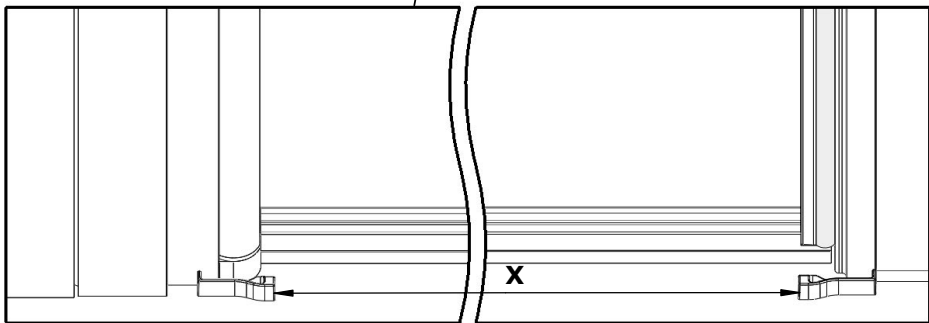
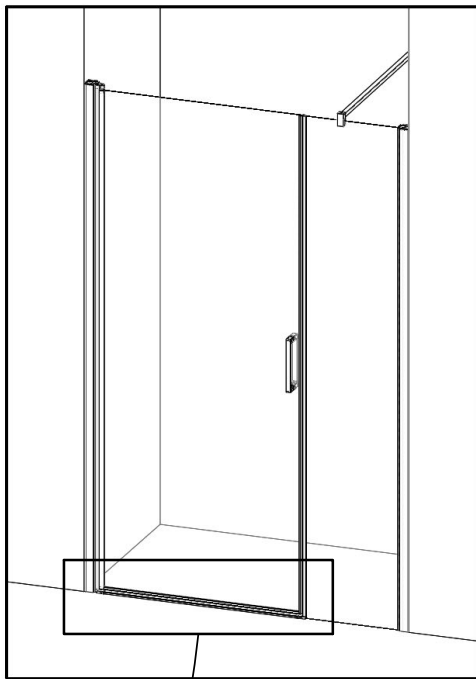

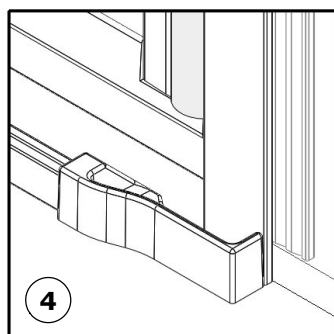
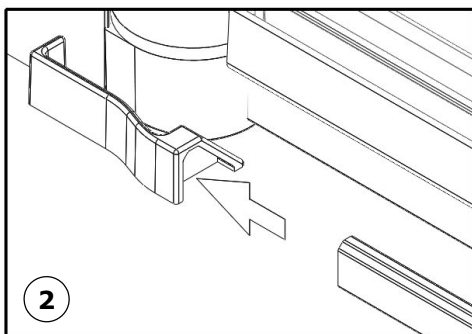
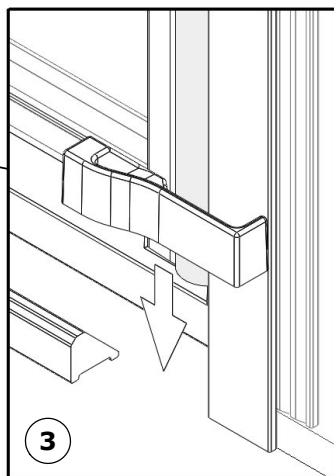
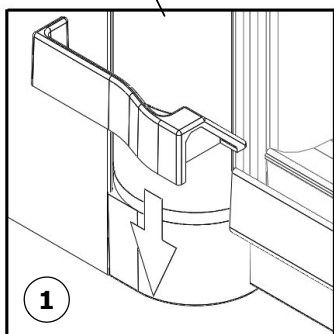
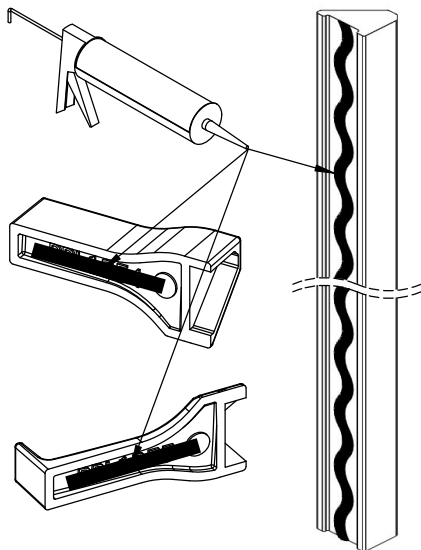
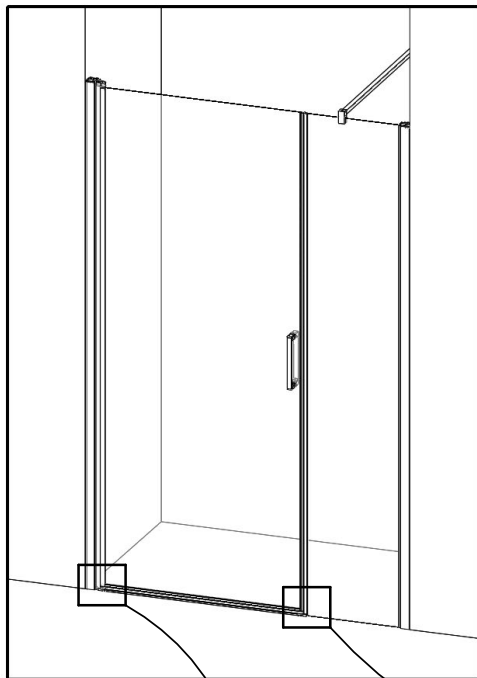



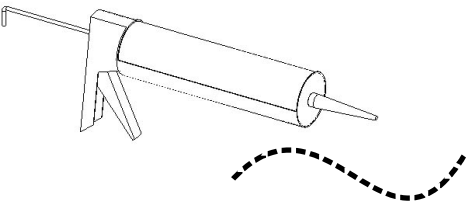

24h

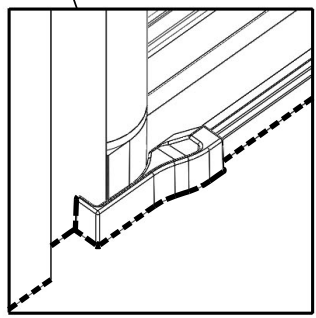
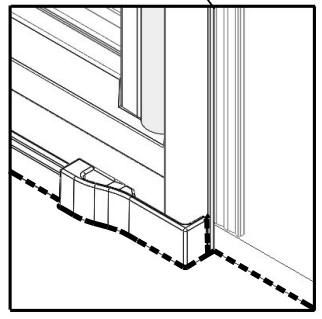
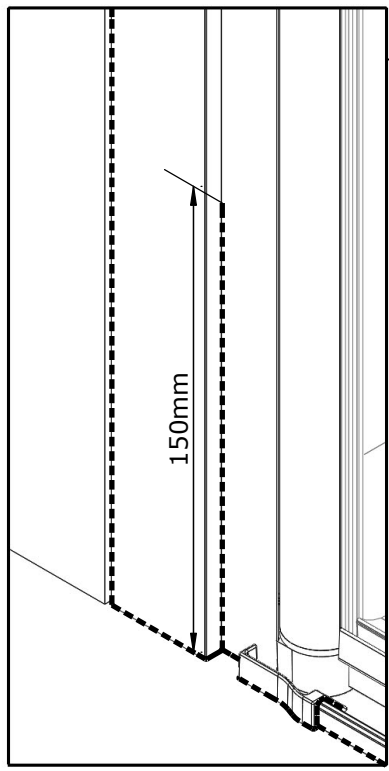
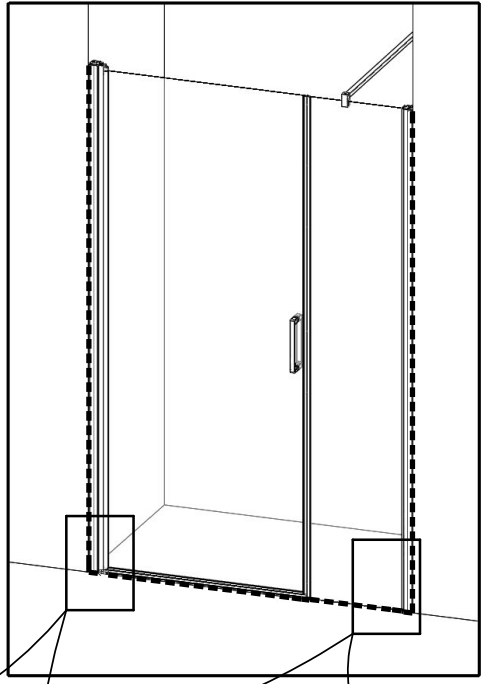



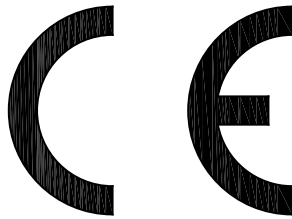

AQUAPRODUCTION, Site industriel,  
F - 44680 Chaumes-en-Retz

18

**EN 14428**

Paroi de douche, fabriquée en verre de silicate  
sodo-calcique de sécurité trempé thermiquement

Aptitude au nettoyage : réussite

Résistance à l'impact/propriétés de fragmentation : réussite

Durabilité : réussite



**SAV**  
**SERVICE HELPLINES**  
**ASSISTENZA POST-VENDITA**  
**SERVICIO POSTVENTA**

**FRANCE**

02 40 21 29 45

**SCHWEIZ**

(01) 748 17 44

**UK**

020 8842 0033

**ESPANA**

93 544 60 76

**IRELAND**

04697 33102

**NEDERLAND**

+31 475 487 100

**DEUTSCHLAND**

+49 (0) 6074 / 30928 0

**BELGIE**

+31 475 487 100

**ITALIA**

(0382) 6181

**BELGIQUE**

+31 475 487 100

**OSTEREICH**

+43 1 710 60 70

**РОССИЯ**

963 19 40, 773 67 22