

Version Standard

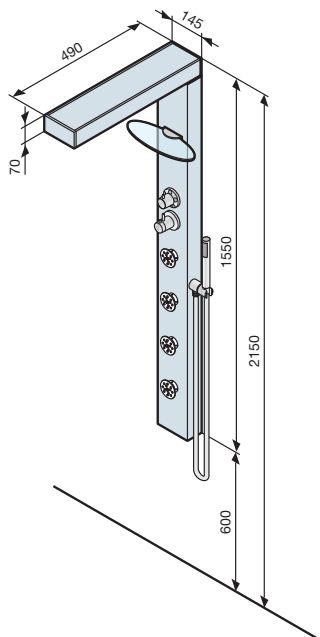

Version Cromolight

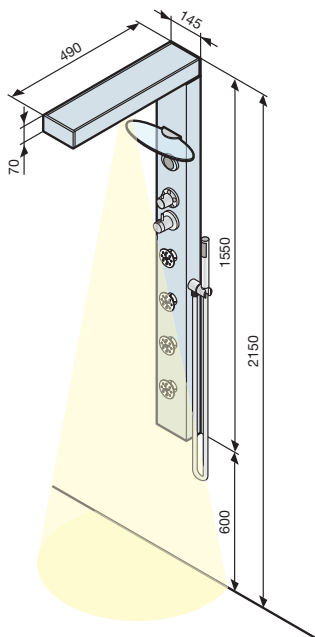

Version Standard avec bec de remplissage

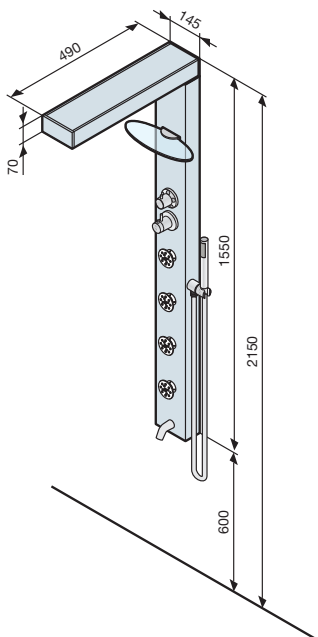

Version Cromolight avec bec de remplissage

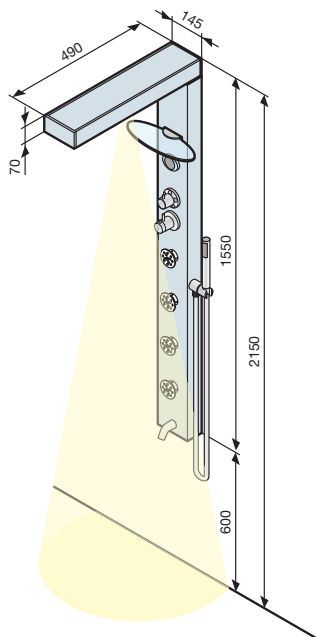

CODE	DESCRIPTION
VERSION STANDARD	
SOUL2VT-B	hydromassage vertical, mitigeur thermostatique, douchette à main, douche zénithale
VERSION CROMOLIGHT	
SOUL2VCRT-B	version standard + cromolight
AVEC BEC DE REMPLISSAGE	
VERSION STANDARD	
SOUL2VTE-B	hydromassage vertical, mitigeur thermostatique, douchette à main, douche zénithale, bec de remplissage
VERSION CROMOLIGHT	
SOUL2VCRTE-B	version standard + cromolight

En stock.

Caractéristiques et données techniques pag. 185.

colonne multifonctions

soul2

- hauteur totale 155 cm

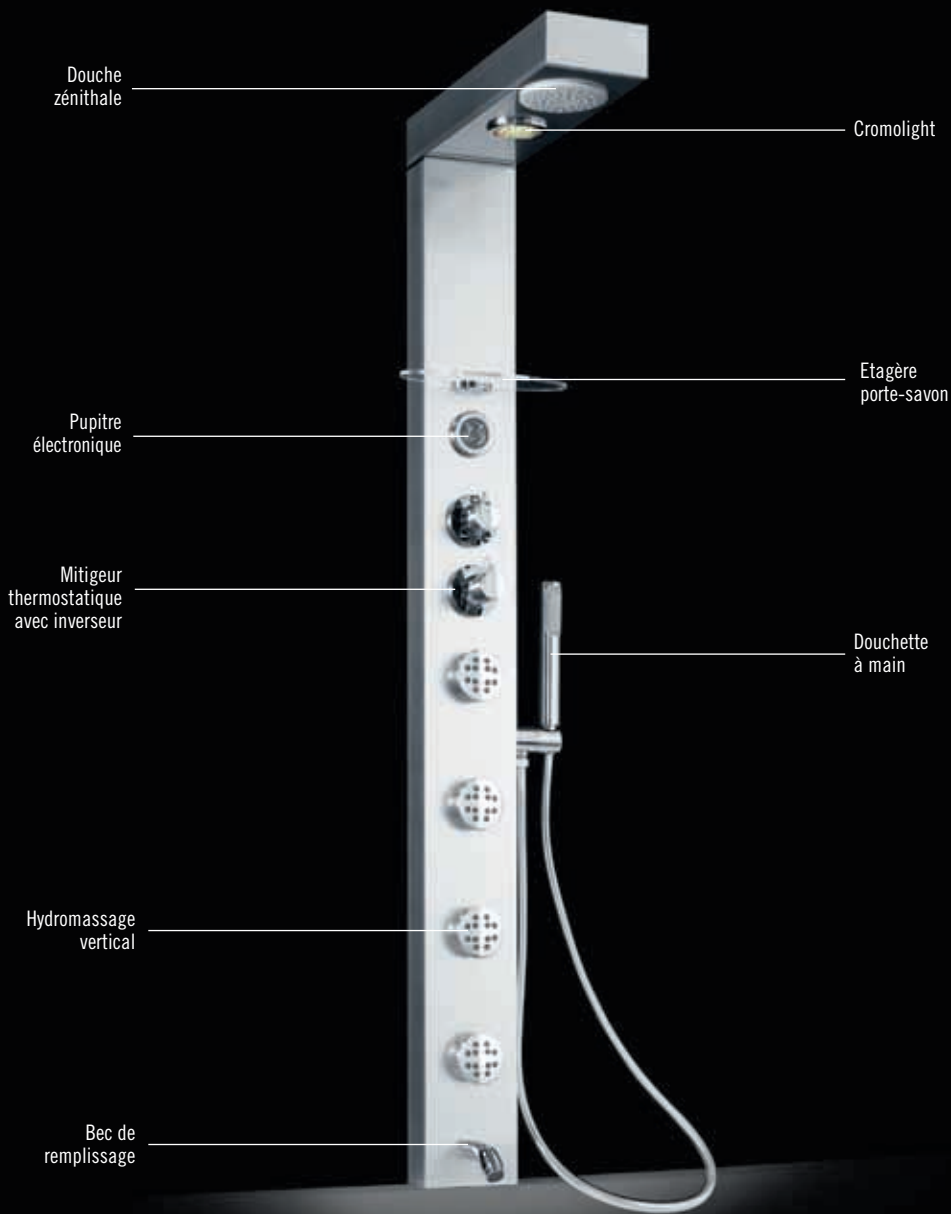

Finitions standards



Douche zénithale Ø 12



Etagère porte-savon

Version avec bec de remplissage



Bec de remplissage

Version cromolight



Cromolight



Pupitre électronique

SOUL 2

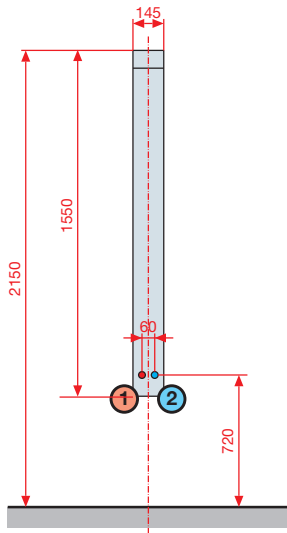

Version Standard

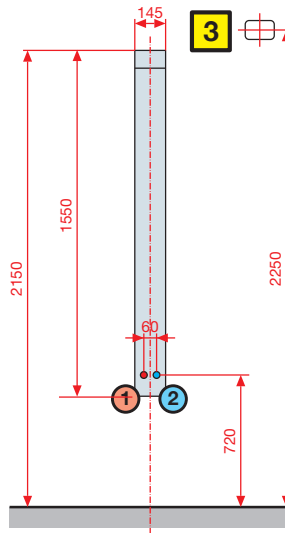

Version Cromlight

SOUL 3

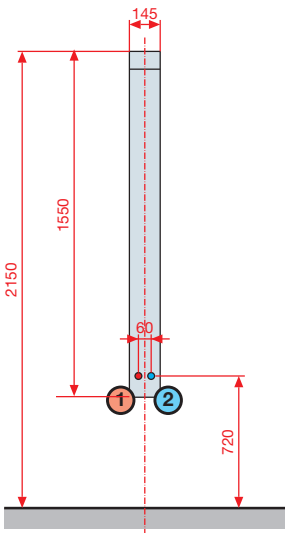

Version au mur

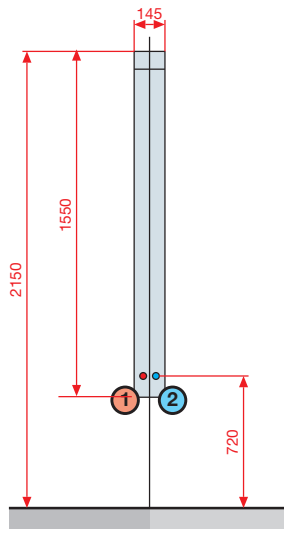

Version d'angle

CARACTERISTIQUES HYDRAULIQUES

- Pressione dinamica ottimale 2÷5 bar
- Raccordement eau chaude 1/2"
- Raccordement eau froide 1/2"

CARACTERISTIQUES ELECTRIQUES

- 230 V
- 50 Hz
- Absorbition maximale: 40 W

En amont de l'appareil, installer un disjoncteur différentiel de 30 mA un coupe-circuit magnétothermique à déconnection omnipolaire distance d'ouverture ≥ 3 mm.